

## 7.5 ton Electric Chain Hoist w/ Power Trolley Variable Speed 440~480V 3φ 1/2 50~60HZ 30ft G100 Nickel Duty H4/M5

### Características Esenciales

- 3 Años de Garantía, Servicio y Atención al Cliente en Mexico

## Especificaciones Técnicas

Capacidad de Carga	7.5 ton	Plug	Open Leads
Altura de Izaje Estandar (Customizable)	30 ft / 9 m	Velocidad /min	1.1~7 ft @60Hz mt @50Hz
Numero de Velocidades	Variable Speed	Voltaje	3 Phase 480V 60Hz
Clase de Servicio	H4/M5/2m/Class D	Protección IEC Motor	IP55
Control	Pendant Control IP66	Voltaje del Control	24V
Tipo Transmisión / Reductor	Spur gearbox	Tipo de Cadena	G100 Nickel
Dimensiones de la Cadena	11.2 mm	Caidas de Cadena	3
Longitud de cadena	90	Humedad	20%~90%
Temperatura	-4 ~ 104° F / -20 ~ 40° C	Potencia del Trolley	750
Velocidad del Trolley /min	5.9~47.23 ft @60Hz 1.5~12 mt @50Hz	Cantidad de Velocidades	Variable
Normas	ASME HST-1 , ASME B30.16 , B30.17 , EN60204-37	Garantía	3 Year
Hoist VFD Power	4kW	Hoist VFD Brand	HUAYUAN
VFD Model	Z230	Brake Resistor Kw	1Kw
IEC Hoist IP Protection	IP55	Pendant Control Yes No	Yes
IEC Pendant Control Protection	IP66	Pendant Control Emergency Stop	Yes
Pendant Control total Length	27 ft	Hoist Motor Power in KW	3
Hoist Motor Brake Type and DC Voltage	DC207V	Overload Protection	Overload Motor Clutch

<b>Trolley Motor Insulation Grade</b>	F	<b>Trolley VFD Power in KW</b>	2.5kW
<b>Trolley VFD Brand</b>	Huayuan	<b>Trolley VFD Model</b>	Z230
<b>Trolley Wheel Diameter</b>	139	<b>Trolley Wheel Material</b>	No. 45 steel
<b>Trolley Minimum Turn Radius</b>	1.8 m / 5.9 ft	<b>Trolley Beam Range</b>	3.9" to 7"
<b>Trolley Beam Extension Kit</b>	up to 12"	<b>Load Chain weight per foot [lbs]</b>	1.83
<b>1st Package Type</b>	Wood Crate	<b>2nd Package Type</b>	Wood Crate

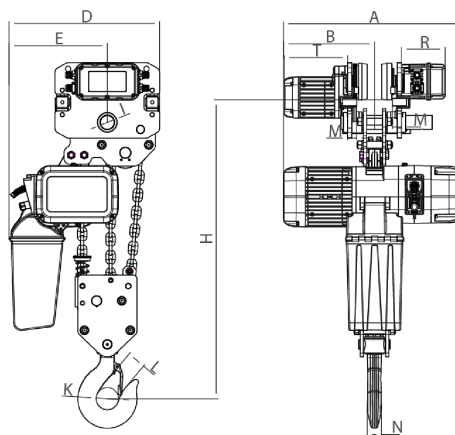

Rated load (t)	Type	Dimension (mm)												
		Minimum distance from the bottom of the track to the bottom hook: H	A	L	B	D	E	I	M	N	K	L	T	R
7	PWRXT7-03	1020	681	3500-5500	350	579	375	54	35	48	85	80	242	167

## Peso & Dimensiones

<b>Peso Total</b>	884 lbs / 402 Kg
-------------------	------------------

## Detalles del Empaque

<b>H Altura Muerta</b>	46.06
<b>A Altura Total</b>	40.16
<b>D Depth</b>	26.81
<b>W Ancho</b>	22.68
<b>J Boca Gancho</b>	3.35
<b>Peso Total (sin cable o cadena)</b>	402.68

Referential Images / Imágenes Referenciales  
Specifications may change without notice / las especificaciones pueden cambiar sin previo aviso