



## **5 ton Electric Chain Hoist w/ Power Trolley 1 Speed 208~240V / 440~480V 3ph 60HZ**

### **Características Esenciales**

- 3 Años de Garantía, Servicio y Atención al Cliente en Mexico

PWRTX5-H4-1S-2/4

## Especificaciones Técnicas

<b>Capacidad de Carga</b>	5 ton	<b>Altura de Izaje Estandar (Customizable)</b>	30 ft / 9 m
<b>Velocidad /min</b>	10.63 ft @60Hz 2.70 mt @50Hz	<b>Numero de Velocidades</b>	1 Speed
<b>Voltaje</b>	3 Phase 208~240/440~480V 50/60Hz	<b>Potencia Total Watts</b>	4000
<b>Clase de Servicio</b>	H4/M5/2m/Class D	<b>Protección IEC Motor</b>	IP55
<b>Control</b>	Pendant Control IP66 and Optional Wireless	<b>Voltaje del Control</b>	24V
<b>Parada de Emergencia</b>	Yes	<b>Tipo Transmisión / Reductor</b>	Spur gearbox
<b>Tipo de Cadena</b>	G100 Nikel	<b>Dimensiones de la Cadena</b>	11.2 mm
<b>Caidas de Cadena</b>	2	<b>Longitud de cadena</b>	60
<b>Humedad</b>	20%~90%	<b>Temperatura</b>	-4 ~ 104° F / -20 ~ 40° C
<b>Potencia del Trolley</b>	750	<b>Velocidad del Trolley /min</b>	43.30 ft @60Hz 11 mt @50Hz
<b>Cantidad de Velocidades</b>	1	<b>Normas</b>	ASME HST-1 , ASME B30.16 , B30.17 , EN60204-36
<b>Garantía</b>	3 Year		

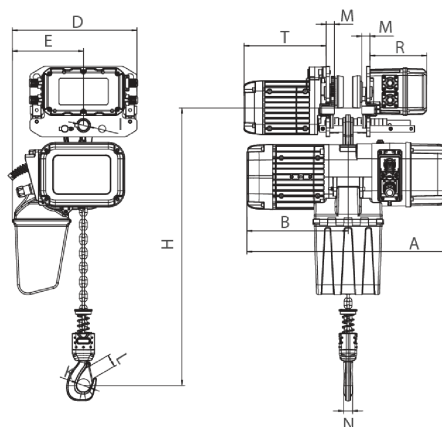

Rated load (t)	Type	Dimension (mm)												
		Minimum distance from the bottom of the track to the bottom hook: H	A	L	B	D	E	I	M	N	K	L	T	R
1	PWRXT1-01	473	440	3500-5500	285	210	20	105	140					
2	PWRXT2-01	516	590		276	368	210	31	24	25	42	32	242	167
3	PWRXT3-01	600	681		350	422	264	36	28	35	52	42	242	167
5	PWRXT5-02	645	681		350	478	307	43	30	34	59	48	242	167

## Peso & Dimensiones

<b>H Altura Muerta</b>	810
<b>A Altura Total</b>	675
<b>D Depth</b>	695
<b>W Ancho</b>	420
<b>J Boca Gancho</b>	60
<b>Peso Total (sin cable o cadena)</b>	185
<b>Peso Total</b>	544 lbs / 247 Kg

## Detalles del Empaque

<b>Paquete 1 Peso Neto</b>	294.8 lbs / 134 Kg
<b>Paquete 1 Peso Bruto</b>	544 lbs / 247 Kg
<b>Paquete 1 Profundidad</b>	30 in / 77 cm
<b>Paquete 1 Ancho</b>	24 in / 61 cm
<b>Paquete 1 Altura</b>	44 in / 112 cm

Referential Images / Imágenes Referenciales  
Specifications may change without notice / las especificaciones pueden cambiar sin previo aviso