



3 ton Electric Chain Hoist w/ Power Trolley 2 Speed 208~240V / 440~480V 3ph 60HZ

3 ton Electric Chain Hoist w/ Power Trolley 2 Speed 208~240V / 440~480V 3ø 60HZ 30ft G100 Nickel Duty H4/M5

Especificaciones Técnicas

Capacidad de Carga	3 ton	Velocidad /min	11.1/ 21.2 ft @60Hz 1.7/5.4 mt @50Hz
Voltaje	3 Phase 208~240/440~480V 50/60Hz	Potencia Total Watts	3500
Clase de Servicio	H4/M5/2m/Class D	Protección IEC Motor	IP55
Tipo Transmisión / Reductor	Spur gearbox	Tipo de Cadena	G100 Nikel
Dimensiones de la Cadena	11.2 mm	Caidas de Cadena	1
Longitud de cadena	30	Humedad	20%~90%
Temperatura	-4 ~ 104° F / -20 ~ 40° C	Potencia del Trolley	500
Velocidad del Trolley /min	14.17~43.30 ft @60Hz 3.6~11 mt @50Hz	Cantidad de Velocidades	2
Normas	ASME HST-1 , ASME B30.16 , B30.17 , EN60204-35	Hoist Contactors Amps	25A
Hoist Contactor Brand	Schneider	Hoist Contactor Coil Voltage	24 V
IEC Hoist IP Protection	IP55	Pendant Control Yes No	Yes
IEC Pendant Control Protection	IP66	Pendant Control Emergency Stop	Yes
Pendant Control total Length	27 ft	Hoist Motor Power in KW	3
Hoist Motor Brake Type and DC Voltage	DC99V/DC207V	Overload Protection	Overload Motor Clutch
Hour Meter	Internal Working Hour Meter	Brake SKU	PWRX-2-20-PN.60.61
Brake rectifiers-half-wave	PWRX-BKTF-HW	Brake rectifiers-full-wave	PWRX-BKTF-FW
Hoist Motor Insulation Grade	F	Power Cord Length and Phase Order	3 ft / Black L1 , Red L2 and Blue L3 □Green ground
Recommended Hoist Protection Circuit Breaker AMPs and Type	Type D 25A at 220V and 20A at 460V	Optional Load Chain Brand & Country of Origin	FEC Japan
Reducer Lubrication Type	Oil	Paint Specifications	Electrostatic Sprayed Plastic (ESP) Epoxy resins, Polyester Resins, Barium, Pigments
Standards Certified	CE	Trolley Motor Brake Type and DC Voltage	DC99V/DC207V
Trolley Motor Insulation Grade	F	Trolley Contactors Amps	32A
Trolley Contactors Brand	Schneider	Trolley Contactors Coil Voltage	24 V
Trolley Wheel Diameter	124	Trolley Wheel Material	No. 45 steel
Trolley Minimum Turn Radius	1.6	Trolley Beam Range	3.9" to 7"
Trolley Beam Extension Kit	up to 12"	Load Chain weight per foot [lbs]	1.83

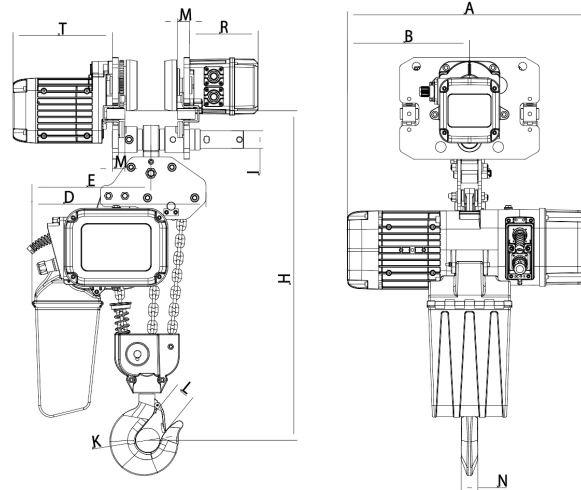

H	A	B	D	E	I	M	N	K	L	T	R
.762	.590	.276	.425	.290	.43	.30	.34	.59	.48	.242	.167

Peso & Dimensiones

H Altura Muerta	645
A Altura Total	645
D Depth	681
W Ancho	350
J Boca Gancho	59
Peso Total (sin cable o cadena)	130
1st Package Type	Wood Crate
2nd Package Type	Wood Crate
Peso Total	517 lbs / 235 Kg

Detalles del Empaque

Paquete 1 Peso Neto	184.8 lbs / 84 Kg
Paquete 1 Peso Bruto	330 lbs / 150 Kg
Paquete 1 Profundidad	30 in / 77 cm
Paquete 1 Ancho	20 in / 51 cm
Paquete 1 Altura	31 in / 79 cm
Paquete 2 Peso Neto	172.7 lbs / 79 Kg
Paquete 2 Peso Bruto	187 lbs / 85 Kg
Paquete 2 Profundidad	11 in / 28 cm
Paquete 2 Ancho	14 in / 36 cm
Paquete 2 Altura	23 in / 59 cm

Referential Images / Imágenes Referenciales
Specifications may change without notice / las especificaciones pueden cambiar sin previo aviso