



20 ton Electric Chain Hoist w/ Power Trolley Variable Speed Trolley 208~240V / 440~480V 3Å, 60HZ

Especificaciones Técnicas

Capacidad de Carga	20 ton	Velocidad /min	5.31 ft @60Hz 1.35 mt @50Hz
Numero de Velocidades	1 Speed	Voltaje	3 Phase 208~240/440~480V 50/60Hz
Potencia Total Watts	7500	Clase de Servicio	H4/M5/2m/Class D
Protección IEC Motor	IP55	Tipo Transmisión / Reductor	Spur gearbox
Tipo de Cadena	G100 Nikel	Dimensiones de la Cadena	11.2 mm
Caidas de Cadena	8	Longitud de cadena	320
Humedad	20%~90%	Temperatura	-4 ~ 104° F / -20 ~ 40° C
Potencia del Trolley	750+750	Velocidad del Trolley /min	2.75~27.55 ft @60Hz 0.7~7 mt @50Hz
Cantidad de Velocidades	Variable	Normas	ASME HST-1 , ASME B30.16 , B30.17 , EN60204-39
Hoist Contactors Amps	25A	Hoist Contactor Brand	Schneider
Hoist Contactor Coil Voltage	24 V	IEC Hoist IP Protection	IP55
Pendant Control Yes No	Yes	IEC Pendant Control Protection	IP66
Pendant Control Emergency Stop	Yes	Pendant Control total Length	37 ft
Hoist Motor Power in KW	3+3	Hoist Motor Brake Type and DC Voltage	DC99V/DC207V
Overload Protection	Overload Motor Clutch	Hour Meter	Internal Working Hour Meter
Brake SKU	PWRX-2-20-PN.60.61	Brake rectifiers-half-wave	PWRX-BKTF-HW
Brake rectifiers-full-wave	PWRX-BKTF-FW	Hoist Motor Insulation Grade	F
Power Cord Length and Phase	2 ft / Black L1, Red L2 and Blue L3	Recommended Hoist Protection	Type D 50A at 220V and 20A at 460V

Trolley VFD Power in KW	2.5KW	Trolley VFD Brand	z-230
Trolley VFD Model	huayuan	Trolley Wheel Diameter	139
Trolley Wheel Material	No. 45 steel	Trolley Minimum Turn Radius	2.2
Trolley Beam Range	5.9" to 8.6"	Trolley Beam Extension Kit	up to 12"
Load Chain weight per foot [lbs]	1.83		

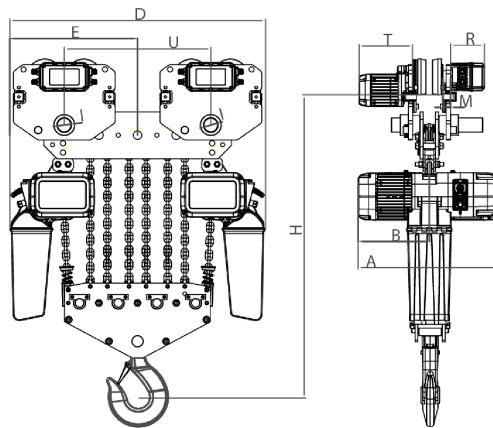

Rated load (t)	Type	Dimension (mm)												
		Minimum distance from the bottom of the track to the bottom hook: H	A	L	B	D	E	I	M	N	K	L	T	R
20	PWRXT20-08	1300	700	3500-5500	350	1246	623	71	40	80	120	96	242	167

Peso & Dimensiones

H Altura Muerta	1240
A Altura Total	1300
D Depth	700
W Ancho	1246
J Boca Gancho	120
Peso Total (sin cable o cadena)	845
1st Package Type	Wood Crate
2nd Package Type	Wood Crate
Peso Total	1848 lbs / 839 Kg

Detalles del Empaque

Paquete 1 Peso Neto	1430 lbs / 649 Kg
Paquete 1 Peso Bruto	1474 lbs / 669 Kg
Paquete 1 Profundidad	55 in / 140 cm
Paquete 1 Ancho	30 in / 77 cm
Paquete 1 Altura	51 in / 130 cm
Paquete 2 Peso Neto	345.4 lbs / 157 Kg
Paquete 2 Peso Bruto	374 lbs / 170 Kg
Paquete 2 Profundidad	11 in / 28 cm
Paquete 2 Ancho	14 in / 36 cm
Paquete 2 Altura	23 in / 59 cm

Referential Images / Imágenes Referenciales
Specifications may change without notice / las especificaciones pueden cambiar sin previo aviso