



2 ton Electric Chain Hoist w/ Power Trolley 2 Speed 208~240V / 440~480V 3ph 60HZ

Características Esenciales

- 3 Años de Garantía, Servicio y Atención al Cliente en Mexico

2 ton Electric Chain Hoist w/ Power Trolley 2 Speed 208~240V / 440~480V 3ø 60HZ 20ft G100 Nickel Duty H4/M5

Especificaciones Técnicas

Capacidad de Carga	2 ton	Altura de Izaje Estandar (Customizable)	20 ft / 6 m
Velocidad /min	8.7/ 26.8 ft @60Hz 2.2/6.8 mt @50Hz	Voltaje	3 Phase 208~240/440~480V 50/60Hz
Potencia Total Watts	3500	Clase de Servicio	H4/M5/2m/Class D
Protección IEC Motor	IP55	Control	Pendant Control IP66 and Optional Wireless
Voltaje del Control	24V	Parada de Emergencia	Yes
Tipo Transmisión / Reductor	Spur gearbox	Tipo de Cadena	G100 Nikel
Dimensiones de la Cadena	10 mm	Caidas de Cadena	1
Longitud de cadena	20	Humedad	20%~90%
Temperatura	-4 ~ 104° F / -20 ~ 40° C	Potencia del Trolley	500
Velocidad del Trolley /min	14.17~43.30 ft @60Hz 3.6~11 mt @50Hz	Cantidad de Velocidades	2
Rango de ancho de la Viga	3" to 7"	Radio Minimo de Giro	1.5
Normas	ASME HST-1 , ASME B30.16 , B30.17 , EN60204-34	Garantía	3 Year

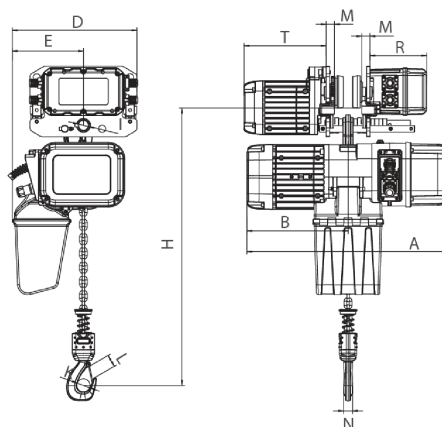

Rated load (t)	Type	Dimension (mm)												
		Minimum distance from the bottom of the track to the bottom hook: H	A	L	B	D	E	I	M	N	K	L	T	R
1	PWRXT1-01	473	440	3500-5500	285	210	20	105	140					
2	PWRXT2-01	516	590		276	368	210	31	24	25	42	32	242	167
3	PWRXT3-01	600	681		350	422	264	36	28	35	52	42	242	167
5	PWRXT5-02	645	681		350	478	307	43	30	34	59	48	242	167

Peso & Dimensiones

H Altura Muerta	600
A Altura Total	600
D Depth	600
W Ancho	422
J Boca Gancho	52
Peso Total (sin cable o cadena)	155
Peso Total	495 lbs / 225 Kg

Detalles del Empaque

Paquete 1 Peso Neto	184.8 lbs / 84 Kg
Paquete 1 Peso Bruto	308 lbs / 140 Kg
Paquete 1 Profundidad	30 in / 77 cm
Paquete 1 Ancho	20 in / 51 cm
Paquete 1 Altura	31 in / 79 cm
Paquete 2 Peso Neto	172.7 lbs / 79 Kg
Paquete 2 Peso Bruto	187 lbs / 85 Kg
Paquete 2 Profundidad	11 in / 28 cm
Paquete 2 Ancho	14 in / 36 cm
Paquete 2 Altura	23 in / 59 cm

