



**2 ton Electric Chain Hoist w/
Power Trolley 1 Speed 208~240V
/ 440~480V 3ph 60HZ 20ft G100
Nickel Duty H4/M5**

2 ton Electric Chain Hoist w/ Power Trolley 1 Speed 208~240V / 440~480V 3ø 60HZ

Especificaciones Técnicas

Capacidad de Carga	2 ton	Velocidad /min	26.77 ft @60Hz 6.80 mt @50Hz
Numero de Velocidades	1 Speed	Voltaje	3 Phase 208~240/440~480V 50/60Hz
Potencia Total Watts	4000	Clase de Servicio	H4/M5/2m/Class D
Protección IEC Motor	IP55	Tipo Transmisión / Reductor	Spur gearbox
Tipo de Cadena	G100 Nikel	Dimensiones de la Cadena	10 mm
Caidas de Cadena	1	Longitud de cadena	20
Humedad	20%~90%	Temperatura	-4 ~ 104° F / -20 ~ 40° C
Potencia del Trolley	500	Velocidad del Trolley /min	43.30 ft @60Hz 11 mt @50Hz
Cantidad de Velocidades	1	Normas	ASME HST-1 , ASME B30.16 , B30.17 , EN60204-34
Hoist Contactors Amps	25A	Hoist Contactor Brand	Schneider
Hoist Contactor Coil Voltage	24 V	IEC Hoist IP Protection	IP55
Pendant Control Yes No	Yes	IEC Pendant Control Protection	IP66
Pendant Control Emergency Stop	Yes	Pendant Control total Length	17 ft
Hoist Motor Power in KW	3	Hoist Motor Brake Type and DC Voltage	DC99V/DC207V
Overload Protection	Overload Motor Clutch	Hour Meter	Internal Working Hour Meter
Brake SKU	PWRX-2-20-PN.60.61	Brake rectifiers-half-wave	PWRX-BKTF-HW
Brake rectifiers-full-wave	PWRX-BKTF-FW	Hoist Motor Insulation Grade	F
Power Cord Length and Phase Order	3 ft / Black L1 , Red L2 and Blue L3 Green ground	Recommended Hoist Protection Circuit Breaker AMPS and Type	Type D 25A at 220V and 20A at 460V
Optional Load Chain Brand & Country of Origin	FEC Japan	Reducer Lubrication Type	Oil
Paint Specifications	Electrostatic Sprayed Plastic (ESP) Epoxy resins, Polyester Resins, Barium, Pigments	Standards Certified	CE
Trolley Motor Brake Type and DC Voltage	DC99V/DC207V	Trolley Motor Insulation Grade	F
Trolley Contactors Amps	32A	Trolley Contactors Brand	Schneider
Trolley Contactors Coil Voltage	24 V	Trolley Wheel Diameter	110
Trolley Wheel Material	No. 45 steel	Trolley Minimum Turn Radius	1.5
Trolley Beam Range	3" to 7"	Trolley Beam Extension Kit	up to 12"
Load Chain weight per foot [lbs]	1.48		

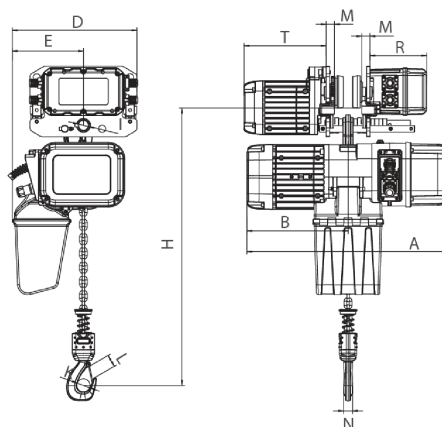

Rated load (t)	Type	Dimension (mm)												
		Minimum distance from the bottom of the track to the bottom hook: H	A	L	B	D	E	I	M	N	K	L	T	R
1	PWRXT1-01	473	440	3500-5500	285	210	20	105	140					
2	PWRXT2-01	516	590		276	368	210	31	24	25	42	32	242	167
3	PWRXT3-01	600	681		350	422	264	36	28	35	52	42	242	167
5	PWRXT5-02	645	681		350	478	307	43	30	34	59	48	242	167

Peso & Dimensiones

H Altura Muerta	600
A Altura Total	540
D Depth	695
W Ancho	420
J Boca Gancho	52
Peso Total (sin cable o cadena)	155
1st Package Type	Wood Crate
2nd Package Type	Wood Crate
Peso Total	418 lbs / 190 Kg

Detalles del Empaque

Paquete 1 Peso Neto	184.8 lbs / 84 Kg
Paquete 1 Peso Bruto	308 lbs / 140 Kg
Paquete 1 Profundidad	30 in / 77 cm
Paquete 1 Ancho	20 in / 51 cm
Paquete 1 Altura	31 in / 79 cm
Paquete 2 Peso Neto	100.1 lbs / 46 Kg
Paquete 2 Peso Bruto	110 lbs / 50 Kg
Paquete 2 Profundidad	11 in / 28 cm
Paquete 2 Ancho	14 in / 36 cm
Paquete 2 Altura	23 in / 59 cm

