



## 10 ton Electric Chain Hoist w/ Power Trolley Variable Speed Trolley 208~240V / 440~480V 3Å, 60HZ

### Especificaciones Técnicas

Capacidad de Carga	10 ton	Velocidad /min	10.63 ft @60Hz 2.70 mt @50Hz
Numero de Velocidades	1 Speed	Voltaje	3 Phase 208~240/440~480V 50/60Hz
Potencia Total Watts	6750	Clase de Servicio	H4/M5/2m/Class D
Protección IEC Motor	IP55	Tipo Transmisión / Reductor	Spur gearbox
Tipo de Cadena	G100 Nikel	Dimensiones de la Cadena	11.2 mm
Caidas de Cadena	4	Longitud de cadena	160
Humedad	20%~90%	Temperatura	-4 ~ 104° F / -20 ~ 40° C
Potencia del Trolley	750	Velocidad del Trolley /min	2.75~27.55 ft @60Hz 0.7~7 mt @50Hz
Cantidad de Velocidades	Variable	Normas	ASME HST-1 , ASME B30.16 , B30.17 , EN60204-38
Hoist Contactors Amps	25A	Hoist Contactor Brand	Schneider
Hoist Contactor Coil Voltage	24 V	IEC Hoist IP Protection	IP55
Pendant Control Yes No	Yes	IEC Pendant Control Protection	IP66
Pendant Control Emergency Stop	Yes	Pendant Control total Length	37 ft
Hoist Motor Power in KW	3+3	Hoist Motor Brake Type and DC Voltage	DC99V/DC207V
Overload Protection	Overload Motor Clutch	Hour Meter	Internal Working Hour Meter
Brake SKU	PWRX-2-20-PN.60.61	Brake rectifiers-half-wave	PWRX-BKTF-HW
Brake rectifiers-full-wave	PWRX-BKTF-FW	Hoist Motor Insulation Grade	F
Power Cord Length and Phase	2 ft / Black L1, Red L2 and Blue L3	Recommended Hoist Protection	Type D 50A at 220V and 20A at 460V

<b>Trolley VFD Power in KW</b>	2.5KW	<b>Trolley VFD Brand</b>	z-230
<b>Trolley VFD Model</b>	huayuan	<b>Trolley Wheel Diameter</b>	139
<b>Trolley Wheel Material</b>	No. 45 steel	<b>Trolley Minimum Turn Radius</b>	2
<b>Trolley Beam Range</b>	3.9" to 7"	<b>Trolley Beam Extension Kit</b>	up to 12"
<b>Load Chain weight per foot [lbs]</b>	1.83		

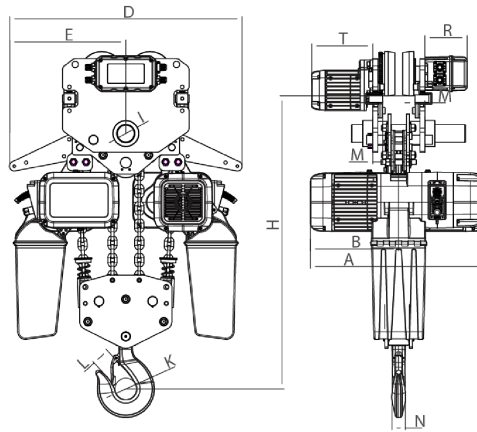

Rated load (t)	Type	Minimum distance from the bottom of the track to the bottom hook: H	Dimension (mm)											
			A	L	B	D	E	I	M	N	K	L	T	R
10	PWRXT10-04	1045	700	3500-5500	350	920	460	70	39	48	85	80	242	167

## Peso & Dimensiones

<b>H Altura Muerta</b>	1005
<b>A Altura Total</b>	1045
<b>D Depth</b>	700
<b>W Ancho</b>	920
<b>J Boca Gancho</b>	85
<b>Peso Total (sin cable o cadena)</b>	345
<b>1st Package Type</b>	Wood Crate
<b>2nd Package Type</b>	Wood Crate
<b>Peso Total</b>	869 lbs / 395 Kg

## Detalles del Empaque

<b>Paquete 1 Peso Neto</b>	638 lbs / 290 Kg
<b>Paquete 1 Peso Bruto</b>	682 lbs / 310 Kg
<b>Paquete 1 Profundidad</b>	44 in / 112 cm
<b>Paquete 1 Ancho</b>	30 in / 77 cm
<b>Paquete 1 Altura</b>	40 in / 102 cm
<b>Paquete 2 Peso Neto</b>	172.7 lbs / 79 Kg
<b>Paquete 2 Peso Bruto</b>	187 lbs / 85 Kg
<b>Paquete 2 Profundidad</b>	11 in / 28 cm
<b>Paquete 2 Ancho</b>	14 in / 36 cm
<b>Paquete 2 Altura</b>	23 in / 59 cm

Referential Images / Imágenes Referenciales  
Specifications may change without notice / las especificaciones pueden cambiar sin previo aviso