



1/4 ton Electric Chain Hoist w/ Power Trolley 1 Speed 208~240V / 440~480V 3Å, 60HZ

Especificaciones Técnicas

Capacidad de Carga	1/4 ton	Velocidad /min	37.79 ft @60Hz 9.6 mt @50Hz
Numero de Velocidades	1 Speed	Voltaje	3 Phase 208~240/440~480V 50/60Hz
Potencia Total Watts	750	Clase de Servicio	H4/M5/2m/Class D
Protección IEC Motor	IP55	Tipo Transmisión / Reductor	Spur gearbox
Tipo de Cadena	G100 Nikel	Dimensiones de la Cadena	5mm
Caidas de Cadena	1	Longitud de cadena	13
Humedad	20%~90%	Temperatura	-4 ~ 104° F / -20 ~ 40° C
Potencia del Trolley	250	Velocidad del Trolley /min	43.30 ft @60Hz 11 mt @50Hz
Cantidad de Velocidades	1	Normas	ASME HST-1 , ASME B30.16 , EN60204-36
Hoist Contactors Amps	10A	Hoist Contactor Brand	Schneider
Hoist UL Components	UL Listed Contactors	Hoist Contactor Coil Voltage	48V
IEC Hoist IP Protection	IP55	Pendant Control Yes No	Yes
IEC Pendant Control Protection	IP66	Pendant Control Emergency Stop	Yes
Pendant Control total Length	10 ft	Hoist Motor Power in KW	0.5
Hoist Motor Brake Type and DC Voltage	DC99V/DC207V	Overload Protection	Overload Motor Clutch
Hour Meter	Internal Working Hour Meter	Brake SKU	PWRX-0.25-0.5-PN.4.11
Brake rectifiers-half-wave	PWRX-BKTF-HW	Brake rectifiers-full-wave	PWRX-BKTF-FW
Hoist Motor Insulation Grade	F	Power Cord Length and Phase	7 ft / Black L1, Red L2 and Blue

Trolley Motor Insulation Grade	F	Trolley Contactors Amps	20A
Trolley Contactors Brand	Schneider	Trolley UL Component	UL Listed
Trolley Contactors Coil Voltage	48V	Trolley Wheel Diameter	95
Trolley Wheel Material	No. 45 steel	Trolley Minimum Turn Radius	1.3
Trolley Beam Range	3" to 5"	Trolley Beam Extension Kit	up to 12"
Load Chain weight per foot [lbs]	0.36		

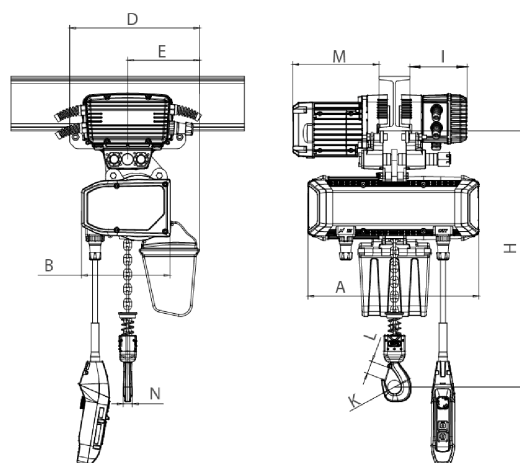

Rated load (t)	Type	Dimension (mm)									
		Minimum distance from the bottom of the track to the bottom hook: H	A	L	B	D	E	I	M	N	K
0.25-0.5	PWRXT0.25-0.5-VS	473	447	3500-5500	217	334	152	147	220	20	35

Peso & Dimensiones

H Altura Muerta	385
A Altura Total	385
D Depth	440
W Ancho	305
J Boca Gancho	35
Peso Total (sin cable o cadena)	56
1st Package Type	Wood Crate
2nd Package Type	Wood Crate
Peso Total	145.2 lbs / 66 Kg

Detalles del Empaque

Paquete 1 Peso Neto	61.16 lbs / 28 Kg
Paquete 1 Peso Bruto	74.8 lbs / 34 Kg
Paquete 1 Profundidad	20 in / 51 cm
Paquete 1 Ancho	15 in / 39 cm
Paquete 1 Altura	20 in / 51 cm
Paquete 2 Peso Neto	62.48 lbs / 29 Kg
Paquete 2 Peso Bruto	70.4 lbs / 32 Kg
Paquete 2 Profundidad	8 in / 21 cm
Paquete 2 Ancho	13 in / 34 cm
Paquete 2 Altura	20 in / 51 cm