



5 ton Electric Chain Hoist 2 Speed 208~240V / 440~480V 3ø 60HZ 30ft G100 Nickel Duty H4/M5

Características Esenciales

- 3 Años de Garantía, Servicio y Atención al Cliente en Mexico

PWRFX5-H4-2S-2/4

Especificaciones Técnicas

Capacidad de Carga	5 ton	Altura de Izaje Estandar (Customizable)	30 ft / 9 m
Velocidad /min	1 st speed : (3.1 ft @60Hz - 0.8 mt @50Hz) / 2 nd speed : (10.6 ft @60Hz - 2.7 mt @50Hz)	Numero de Velocidades	2 Speed
Voltaje	3 Phase 208~240/480V 50/60Hz	Clase de Servicio	H4/M5/2m/Class D
Protección IEC Motor	IP55	Control	Pendant Control IP66
Voltaje del Control	24V	Tipo Transmisión / Reductor	Spur gearbox
Tipo de Cadena	G100 Nickel	Dimensiones de la Cadena	11.2 mm
Caidas de Cadena	2	Longitud de cadena	60
Humedad	20%~90%	Temperatura	-4 ~ 104° F / -20 ~ 40° C
Normas	ASME HST-1 , ASME B30.16	Garantía	3 Year
Hoist Contactors Amps	25A	Hoist Contactor Brand	Schneider
Hoist Contactor Model	LC1D25B7C / LC1D25B7C	Hoist Contactor Coil Voltage	24 V
IEC Hoist IP Protection	IP55	Pendant Control Yes No	Yes
IEC Pendant Control Protection	IP66	Pendant Control Emergency Stop	Yes
Pendant Control total Length	27 ft	Hoist Motor Power in KW	3
Hoist Motor Brake Type and DC Voltage	DC99V/DC207V	Overload Protection	Overload Motor Clutch
Hour Meter	Internal Working Hour Meter	Brake rectifiers-half-wave	PWRX-BKTF-HW
Brake rectifiers-full-wave	PWRX-BKTF-FW	Hoist Motor Insulation Grade	F
Recommended Hoist Protection Circuit Breaker AMPs and Type	Type D 25A at 220-240V and 12A at 460-480V	Optional Load Chain Brand & Country of Origin	FEC Japan
Reducer Lubrication Type	Oil	Paint Specifications	Electrostatic Sprayed Plastic (ESP) Epoxy resins, Polyester Resins, Barium, Pigments
Standards Certified	EN60204-36, ASME HST-1 , ASME B30.16 , EN60204-36, EN ISO 12100:2010, EN 14492-2:2019, EN 60204-1:2018+A1:2025, EN IEC 61000-6-2:2019, EN IEC 61000-6-4:2019, EN IEC 61000-3-2:2019+A2:2024, EN 61000-3-3:2013+A2:2021	Load Chain weight per foot [lbs]	1.83
1st Package Type	Wood Crate		

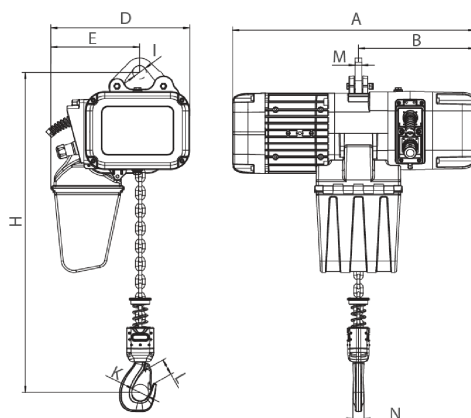

[Size list: mm]

Rated load (t)	Type	Minimum distance between hooks: H	A	B	D	E	I	M	N	K	L
1	PWRXF1-01	455	590	276	330	210	32	16	25	42	32
2	PWRXF2-01	550	590	276	330	210	38	20	35	52	42
3	PWRXF3-01	560	695	350	420	265	45	20	34	59	48
5	PWRXF5-02	675	695	350	420	307	55	28	44	60	48

Peso & Dimensiones

Peso Total 368 lbs / 167 Kg

Detalles del Empaque

H Altura Muerta 31.89

A Altura Total 26.57

D Depth 27.36

W Ancho 16.54

J Boca Gancho 2.36

Peso Total (sin cable o cadena) 213.46

Referential Images / Imágenes Referenciales
Specifications may change without notice / las especificaciones pueden cambiar sin previo aviso