



10 ton Electric Chain Hoist 1 Speed 380V 3ø 50HZ

Características Esenciales

- 3 Años de Garantía, Servicio y Atención al Cliente en Mexico

Especificaciones Técnicas

Capacidad de Carga	10 ton	Altura de Izaje Estandard (Customizable)	40 ft / 12 m
Velocidad /min	10.63 ft @60Hz 2.70 mt @50Hz	Numero de Velocidades	1 Speed
Voltaje	3 Phase 380V 50Hz	Potencia Total Watts	6000
Clase de Servicio	H4/M5/2m/Class D	Protección IEC Motor	IP55
Control	Pendant Control IP66 and Optional Wireless	Voltaje del Control	24V
Parada de Emergencia	Yes	Tipo Transmisión / Reductor	Spur gearbox
Tipo de Cadena	G100 Nikel	Dimensiones de la Cadena	11.2 mm
Caidas de Cadena	4	Longitud de cadena	160
Humedad	20%~90%	Temperatura	-4 ~ 104° F / -20 ~ 40° C
Normas	ASME HST-1 , ASME B30.16 , EN60204-38	Garantía	3 Year
Hoist Contactors Amps	25A	Hoist Contactor Brand	Schneider
Hoist Contactor Coil Voltage	24 V	IEC Hoist IP Protection	IP55
IEC Pendant Control Protection	IP66	Hoist Motor Power in KW	3+3
Hoist Motor Brake Type and DC Voltage	DC170V	Hour Meter	Internal Working Hour Meter
Hoist Motor Insulation Grade	F		

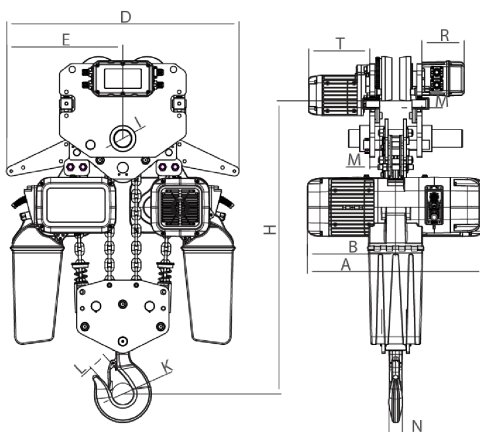

Rated load (t)	Type	Dimension (mm)												
		Minimum distance from the bottom of the track to the bottom hook: H	A	L	B	D	E	I	M	N	K	L	T	R
10	PWRXT10-04	1045	700	3500-5500	350	920	460	70	39	48	85	80	242	167

Peso & Dimensiones

H Altura Muerta	1005
A Altura Total	1200
D Depth	700
W Ancho	920
J Boca Gancho	85
Peso Total (sin cable o cadena)	345
1st Package Type	Wood Crate
Peso Total	682 lbs / 310 Kg

Detalles del Empaque

Paquete 1 Peso Neto	638 lbs / 290 Kg
Paquete 1 Peso Bruto	682 lbs / 310 Kg
Paquete 1 Profundidad	44 in / 112 cm
Paquete 1 Ancho	30 in / 77 cm
Paquete 1 Altura	40 in / 102 cm

Referential Images / Imágenes Referenciales
Specifications may change without notice / las especificaciones pueden cambiar sin previo aviso