



## **10 ton Electric Chain Hoist 1 Speed 208~240V / 440~480V 3Ø 60HZ 40ft G100 Nickel Duty H4/M5**

### **Características Esenciales**

- 3 Años de Garantía, Servicio y Atención al Cliente en Mexico

PWRXF10-H4-1S-2/4

## Especificaciones Técnicas

<b>Capacidad de Carga</b>	10 ton	<b>Velocidad /min</b>	10.63 ft @60Hz 2.70 mt @50Hz
<b>Numero de Velocidades</b>	1 Speed	<b>Voltaje</b>	3 Phase 208~240/440~480V 50/60Hz
<b>Potencia Total Watts</b>	6000	<b>Clase de Servicio</b>	H4/M5/2m/Class D
<b>Protección IEC Motor</b>	IP55	<b>Tipo Transmisión / Reductor</b>	Spur gearbox
<b>Tipo de Cadena</b>	G100 Nikel	<b>Dimensiones de la Cadena</b>	11.2 mm
<b>Caidas de Cadena</b>	4	<b>Longitud de cadena</b>	160
<b>Humedad</b>	20%~90%	<b>Temperatura</b>	-4 ~ 104° F / -20 ~ 40° C
<b>Normas</b>	ASME HST-1 , ASME B30.16 , EN60204-38	<b>Hoist Contactors Amps</b>	25A
<b>Hoist Contactor Brand</b>	Schneider	<b>Hoist UL Components</b>	UL Listed Contactors
<b>Hoist Contactor Coil Voltage</b>	24 V	<b>IEC Hoist IP Protection</b>	IP55
<b>Pendant Control Yes No</b>	Yes	<b>IEC Pendant Control Protection</b>	IP66
<b>Pendant Control Emergency Stop</b>	Yes	<b>Pendant Control total Length</b>	37 ft
<b>Hoist Motor Power in KW</b>	3+3	<b>Hoist Motor Brake Type and DC Voltage</b>	DC99V/DC207V
<b>Overload Protection</b>	Overload Motor Clutch	<b>Hour Meter</b>	Internal Working Hour Meter
<b>Brake SKU</b>	PWRX-2-20-PN.60.61	<b>Brake rectifiers-half-wave</b>	PWRX-BKTF-HW
<b>Brake rectifiers-full-wave</b>	PWRX-BKTF-FW	<b>Hoist Motor Insulation Grade</b>	F
<b>Power Cord Length and Phase Order</b>	3 ft / Black L1 , Red L2 and Blue L3 Green ground	<b>Recommended Hoist Protection Circuit Breaker AMPs and Type</b>	Type D 50A at 220V and 30A at 460V
<b>Optional Load Chain Brand &amp; Country of Origin</b>	FEC Japan	<b>Reducer Lubrication Type</b>	Oil
<b>Paint Specifications</b>	Electrostatic Sprayed Plastic (ESP) Epoxy resins, Polyester Resins, Barium, Pigments	<b>Standards Certified</b>	CE
<b>Load Chain weight per foot [lbs]</b>	1.83		

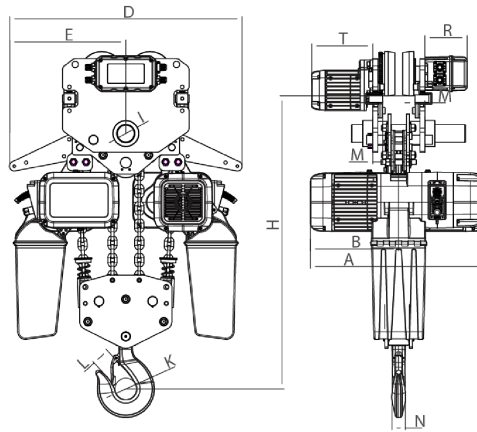

Rated load (t)	Type	Dimension (mm)												
		Minimum distance from the bottom of the track to the bottom hook: H	A	L	B	D	E	I	M	N	K	L	T	R
10	PWRXT10-04	1045	700	3500-5500	350	920	460	70	39	48	85	80	242	167

## Peso & Dimensiones

<b>H Altura Muerta</b>	1005
<b>A Altura Total</b>	1200
<b>D Depth</b>	700
<b>W Ancho</b>	920
<b>J Boca Gancho</b>	85
<b>Peso Total (sin cable o cadena)</b>	345
<b>1st Package Type</b>	Wood Crate
<b>Peso Total</b>	682 lbs / 310 Kg

## Detalles del Empaque

<b>Paquete 1 Peso Neto</b>	638 lbs / 290 Kg
<b>Paquete 1 Peso Bruto</b>	682 lbs / 310 Kg
<b>Paquete 1 Profundidad</b>	44 in / 112 cm
<b>Paquete 1 Ancho</b>	30 in / 77 cm
<b>Paquete 1 Altura</b>	40 in / 102 cm

Referential Images / Imágenes Referenciales  
Specifications may change without notice / las especificaciones pueden cambiar sin previo aviso