



1 ton Electric Chain Hoist 1 Speed 208~240V / 440~480V 3ph 60HZ

Características Esenciales

- 3 Años de Garantía, Servicio y Atención al Cliente en Mexico

1 ton Electric Chain Hoist 1 Speed 208~240V / 440~480V 3ø 60HZ 20ft G100 Nickel Duty H4/M5

Especificaciones Técnicas

Capacidad de Carga	1 ton	Altura de Izaje Estandar (Customizable)	20 ft / 6 m
Velocidad /min	25.60 ft @60Hz 6.50 mt @50Hz	Numero de Velocidades	1 Speed
Voltaje	3 Phase 208~240/440~480V 50/60Hz	Potencia Total Watts	1500
Clase de Servicio	H4/M5/2m/Class D	Protección IEC Motor	IP55
Control	Pendant Control IP66 and Optional Wireless	Voltaje del Control	24V
Parada de Emergencia	Yes	Tipo Transmisión / Reductor	Spur gearbox
Tipo de Cadena	G100 Nikel	Dimensiones de la Cadena	7.1 mm
Caidas de Cadena	1	Longitud de cadena	20
Humedad	20%~90%	Temperatura	-4 ~ 104° F / -20 ~ 40° C
Normas	ASME HST-1 , ASME B30.16 , EN60204-33	Garantía	3 Year
Hoist Contactors Amps	18A	Hoist Contactor Brand	Schneider
Hoist UL Components	UL Listed Contactors	Hoist Contactor Coil Voltage	24 V
IEC Hoist IP Protection	IP55	IEC Pendant Control Protection	IP66
Hoist Motor Power in KW	1.5	Hoist Motor Brake Type and DC Voltage	DC99V/DC207V
Hour Meter	Internal Working Hour Meter	Hoist Motor Insulation Grade	F

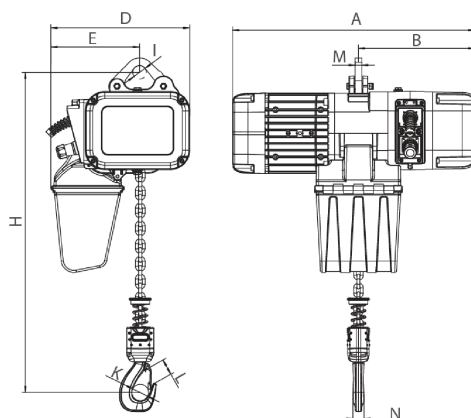

[Size list: mm]

Rated load (t)	Type	Minimum distance between hooks: H	A	B	D	E	I	M	N	K	L
1	PWRXF1-01	455	590	276	330	210	32	16	25	42	32
2	PWRXF2-01	550	590	276	330	210	38	20	35	52	42
3	PWRXF3-01	560	695	350	420	265	45	20	34	59	48
5	PWRXF5-02	675	695	350	420	307	55	28	44	60	48

Peso & Dimensiones

H Altura Muerta 516

A Altura Total 455

D Depth 590

W Ancho 330

J Boca Gancho 42

Peso Total (sin cable o cadena) 86

1st Package Type Wood Crate

Peso Total 150 lbs / 69 Kg

Detalles del Empaque

Paquete 1 Peso Neto 101.64 lbs / 47 Kg

Paquete 1 Peso Bruto 150 lbs / 69 Kg

Paquete 1 Profundidad 26 in / 67 cm

Paquete 1 Ancho 16 in / 41 cm

Paquete 1 Altura 28 in / 72 cm

Referential Images / Imágenes Referenciales
Specifications may change without notice / las especificaciones pueden cambiar sin previo aviso