



1/2 ton Electric Chain Hoist 1 Speed 208~240V / 440~480V 3ph 60HZ

Características Esenciales

- 3 Años de Garantía, Servicio y Atención al Cliente en Mexico

1/2 ton Electric Chain Hoist 1 Speed 208~240V / 440~480V 3ø 60HZ 13ft G100 Nickel Duty H4/M5

Especificaciones Técnicas

Capacidad de Carga	1/2 ton	Altura de Izaje Estandar (Customizable)	13 ft / 4 m
Velocidad /min	31.49 ft @60Hz 8 mt @50Hz	Numero de Velocidades	1 Speed
Voltaje	3 Phase 208~240/440~480V 50/60Hz	Potencia Total Watts	750
Clase de Servicio	H4/M5/2m/Class D	Protección IEC Motor	IP55
Control	Pendant Control IP66 and Optional Wireless	Voltaje del Control	48V
Parada de Emergencia	Yes	Tipo Transmisión / Reductor	Spur gearbox
Tipo de Cadena	G100 Nikel	Dimensiones de la Cadena	6.3mm
Caidas de Cadena	1	Longitud de cadena	13
Humedad	20%~90%	Temperatura	-4 ~ 104° F / -20 ~ 40° C
Normas	ASME HST-1 , ASME B30.16 , EN60204-37	Garantía	3 Year
Hoist Contactors Amps	10A	Hoist Contactor Brand	Schneider
Hoist UL Components	UL Listed Contactors	Hoist Contactor Coil Voltage	48V
IEC Hoist IP Protection	IP55	IEC Pendant Control Protection	IP66
Hoist Motor Power in KW	0.75	Hoist Motor Brake Type and DC Voltage	DC99V/DC207V
Hour Meter	Internal Working Hour Meter	Hoist Motor Insulation Grade	F

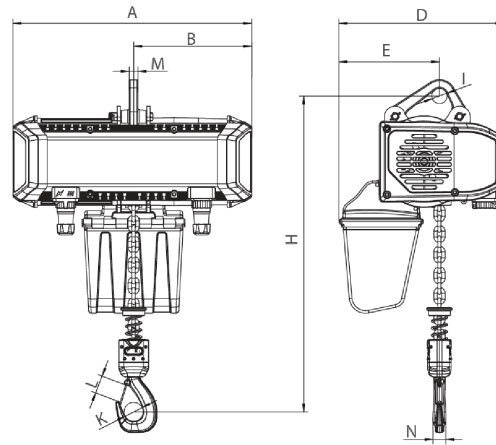

[Size list: mm]

Rated load (t)	Type	Minimum distance between hooks: H	A	B	D	E	I	M	N	K	L
0.25-0.5	PWRXF0.25-0.5-VS	399	447	217	337	179	31	16	20	35	31

Peso & Dimensiones

H Altura Muerta	396
A Altura Total	396
D Depth	440
W Ancho	305
J Boca Gancho	35
Peso Total (sin cable o cadena)	53
1st Package Type	Wood Crate
Peso Total	74.8 lbs / 34 Kg

Detalles del Empaque

Paquete 1 Peso Neto	61.16 lbs / 28 Kg
Paquete 1 Peso Bruto	74.8 lbs / 34 Kg
Paquete 1 Profundidad	20 in / 51 cm
Paquete 1 Ancho	15 in / 39 cm
Paquete 1 Altura	20 in / 51 cm

Referential Images / Imágenes Referenciales
Specifications may change without notice / las especificaciones pueden cambiar sin previo aviso