



1/4 ton Electric Chain Hoist 1 Speed 208~240V / 440~480V 3ø 60HZ 13ft G100 Nickel Duty H4/M5

Características Esenciales

- 3 Años de Garantía, Servicio y Atención al Cliente en Mexico

PWRXF0.25-H4-1S-2/4

Especificaciones Técnicas

Capacidad de Carga	1/4 ton	Velocidad /min	37.79 ft @60Hz 9.6 mt @50Hz
Numero de Velocidades	1 Speed	Voltaje	3 Phase 208~240/440~480V 50/60Hz
Potencia Total Watts	500	Clase de Servicio	H4/M5/2m/Class D
Protección IEC Motor	IP55	Tipo Transmisión / Reductor	Spur gearbox
Tipo de Cadena	G100 Nikel	Dimensiones de la Cadena	5mm
Caidas de Cadena	1	Longitud de cadena	13
Humedad	20%~90%	Temperatura	-4 ~ 104° F / -20 ~ 40° C
Normas	ASME HST-1 , ASME B30.16 , EN60204-36	Hoist Contactors Amps	10A
Hoist Contactor Brand	Schneider	Hoist UL Components	UL Listed Contactors
Hoist Contactor Coil Voltage	48V	IEC Hoist IP Protection	IP55
Pendant Control Yes No	Yes	IEC Pendant Control Protection	IP66
Pendant Control Emergency Stop	Yes	Pendant Control total Length	10 ft
Hoist Motor Power in KW	0.5	Hoist Motor Brake Type and DC Voltage	DC99V/DC207V
Overload Protection	Overload Motor Clutch	Hour Meter	Internal Working Hour Meter
Brake SKU	PWRX-0.25-0.5-PN.4.11	Brake rectifiers-half-wave	PWRX-BKTF-HW
Brake rectifiers-full-wave	PWRX-BKTF-FW	Hoist Motor Insulation Grade	F
Power Cord Length and Phase Order	3 ft / Black L1 , Red L2 and Blue L3 Green ground	Recommended Hoist Protection Circuit Breaker AMPs and Type	Type D 15A at 220V and 10A at 460V
Optional Load Chain Brand & Country of Origin	FEC Japan	Reducer Lubrication Type	Oil
Paint Specifications	Electrostatic Sprayed Plastic (ESP) Epoxy resins, Polyester Resins, Barium, Pigments	Standards Certified	CE
Load Chain weight per foot [lbs]	0.36		

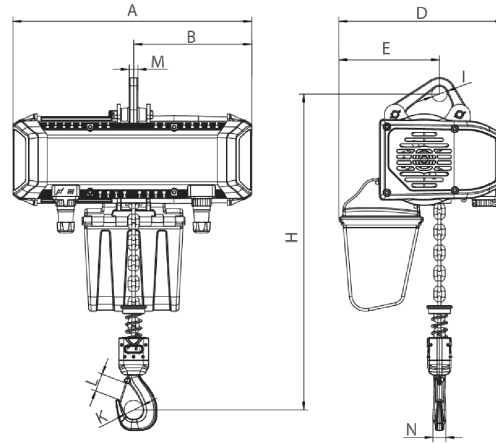

[Size list: mm]

Rated load (t)	Type	Minimum distance between hooks: H	A	B	D	E	I	M	N	K	L
0.25-0.5	PWRXF0.25-0.5-VS	399	447	217	337	179	31	16	20	35	31

Peso & Dimensiones

H Altura Muerta	385
A Altura Total	385
D Depth	440
W Ancho	305
J Boca Gancho	35
Peso Total (sin cable o cadena)	56
1st Package Type	Wood Crate
Peso Total	74.8 lbs / 34 Kg

Detalles del Empaque

Paquete 1 Peso Neto	61.16 lbs / 28 Kg
Paquete 1 Peso Bruto	74.8 lbs / 34 Kg
Paquete 1 Profundidad	20 in / 51 cm
Paquete 1 Ancho	15 in / 39 cm
Paquete 1 Altura	20 in / 51 cm

Referential Images / Imágenes Referenciales
Specifications may change without notice / las especificaciones pueden cambiar sin previo aviso