



Tecle Cadena Neumatico 10 Tons

Características Esenciales

- 10 Tons Pneumatic Chain Hoist - Heavy Duty - Explosion Proof
- RUD G80 chain made in Germany - 7 meters lifting height (other heights available upon request)
- Includes: Overload Protection - Slip Clutch / Failsafe Automatic Internal Break / Pendant Control with emergency stop (9 meters) / Chain containers
- Meets and exceeds ASME B30.16 / HST-5 standards / Load Test at 130% SWL / ATEX Directive
- 3 Años de Garantía, Servicio y Atención al Cliente en Mexico

Especificaciones Técnicas

Capacidad de Carga	10 Ton	Altura de Izaje Estandard (Customizable)	20 ft / 6 m
Numero de Velocidades	1 Speed	Velocidad de Izaje a Plena Carga	1.3 m/min
Velocidad de Izaje Sin Carga	2.8 m/min	Velocidad de Bajada a Plena Carga	2.4 m/min
Máxima Sobrecarga Segura	Overload Protection Slip Clutch 130% WLL	Protección Antiexplosión	- EX 2 GD IIA T4 - EX 2 GD IIB T4 - EXCLUDES Hydrogen Disulphide or Ethelene Oxide - ZONES 1, 2 AND 21, 22
Exclusiones de Proteccion	- HYDROGEN DISULPHIDE - ETHELENE OXIDE	Distancia de Control	16 ft / 5 m
Clase de Servicio	100% Duty Cycle	Tipo de Motor	Vane Rotary Motor - Lubrication Free - Rust Free & Replaceable Stainless Steel Cylinder
Potencia Motor	3.2 kw	Freno Motor	>125% WLL Automatic self-adjusting multidisc Brake
Control	Pendant Control w/emergency stop	Parada de Emergencia	Yes
Rango de temperatura de Trabajo	-20°C to 70°C	Presión Aire	4 - 6 Bar
Dimensión Entrada Aire	3/4 BSP	Dimensión Tuberia Aire	19mm - 25mm (3/4" - 1")
Consumo Aire	1.75 m3/min	Tipo Transmisión / Reductor	Epicyle Gearbox (Grease Filled and Sealed)
Tipo de Cadena	G80 RUG Germany 5:1 Safety Factor	Dimensiones de la Cadena	16 x 45 mm
Caidas de Cadena	2	Temperatura	-20°C to 70°C
Nivel de Ruido	84 dBA @ 1m	Normas	ASME B30.11 /B30.16 /HST-5 DIN EN818-7

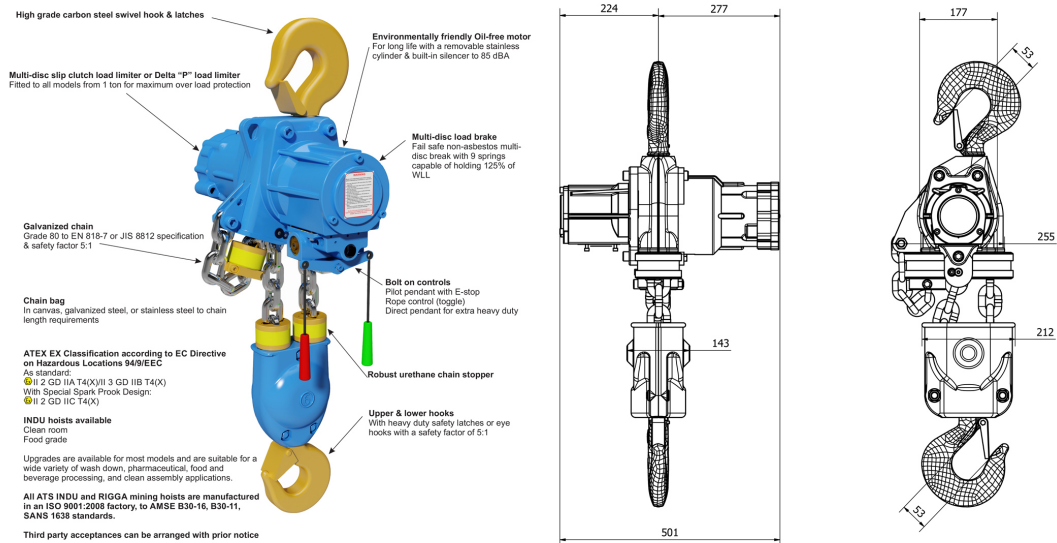

Peso & Dimensiones

H Altura Muerta

802 mm

Referential Images / Imágenes Referenciales

Specifications may change without notice / las especificaciones pueden cambiar sin previo aviso