



Polipasto Cadena con Carro - Neumatico Anti explosion ATEX - Nickel Kit 1,5 tons

Características Esenciales

- 1.5 Tons Pneumatic Chain Hoist with trolley - Heavy Duty - Explosion Proof with Nickel Coatings Upgrade
- RUD G80 chain made in Germany - 9 meters lifting height (other heights available upon request) Safety factor 5:1
- Includes: Multi-disc slip clutch load limiter / Pendant Control with emergency stop (8 meters) / Chain containers
- Meets and exceeds ASME B30.16 B30.17 / HST-5 standards / Load Test at 130% SWL / ATEX Directive
- 3 Años de Garantía, Servicio y Atención al Cliente en Mexico

Especificaciones Técnicas

Capacidad de Carga	1.5 Ton	Altura de Izaje Estandard (Customizable)	20 ft / 6 m
Numero de Velocidades	1 Speed	Velocidad de Izaje a Plena Carga	8.8 m/min
Velocidad de Izaje Sin Carga	13 m/min	Velocidad de Bajada a Plena Carga	13.5 m/min
Máxima Sobrecarga Segura	Overload Protection Slip Clutch 130% WLL	Protección Antiexplosión	EX 2 GD IIA T4 EX 2 GD IIB T4 EX 2 GD IIC T4 ZONES 1, 2 AND 21, 22 - Nickel Coated: Chain hook, bottom block, Sprocket, Load sleeve, Safety Catch - Stainless Steel Wheels
Exclusiones de Proteccion	- HYDROGEN DISULPHIDE - ETHELENE OXIDE	Clase de Servicio	100% Duty Cycle
Tipo de Motor	Vane Rotary Motor - Lubrication Free - Rust Free & Replaceable Stainless Steel Cylinder	Potencia Motor	1.4 kw
Freno Motor	>125% WLL Automatic self-adjusting multidisc Brake	Control	Pendant Control 4 buttons w/emergency stop
Parada de Emergencia	Yes, on pendant Control	Rango de temperatura de Trabajo	-20°C to 70°C
Presión Aire	4 - 6 Bar	Dimensión Entrada Aire	1/2" BSP
Dimensión Tuberia Aire	13 mm (1/2")	Consumo Aire	75 cfm / 2.1 m3/min
Tipo Transmisión / Reductor	Epicycle Gearbox (Grease Filled and Seald)	Tipo de Cadena	G80 RUG Germany 5:1 Safety Factor
Dimensiones de la Cadena	9 x 27 mm	Caidas de Cadena	1

EC Directive on Hazardous Locations
94/9/EEC

Fabricado en	Southafrica	Garantía	3 Year
---------------------	-------------	-----------------	--------

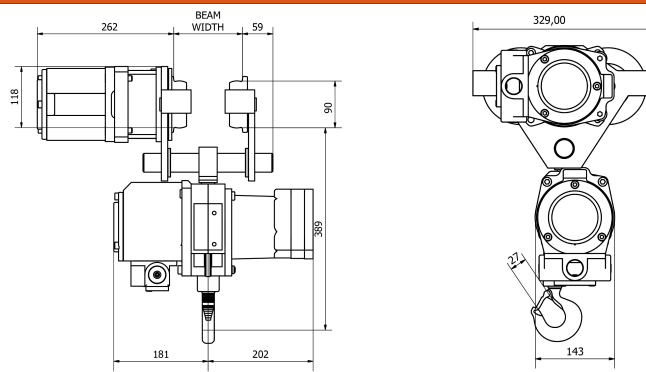

Peso & Dimensiones

H Altura Muerta

402 mm

Referential Images / Imágenes Referenciales
Specifications may change without notice / las especificaciones pueden cambiar sin previo aviso