



## Carro Electrico 3 Fases 2 Toneladas. Botonera No Incluida

### Características Esenciales

- 3 Años de Garantía, Servicio y Atención al Cliente en Mexico

## Especificaciones Técnicas

|                                  |                       |                                   |   |
|----------------------------------|-----------------------|-----------------------------------|---|
| <b>Capacidad de Carga</b>        | 4400 lb / 2000 kg     | <b>Voltaje</b>                    | 3 Phase 208~240/440~480V 50/60Hz          |
| <b>Potencia Total Watts</b>      | 0.4 kW                | <b>Velocidad del Trolley /min</b> | 43 ft / 13 m @ 60 HZ   36 ft / 11 @ 50 HZ |
| <b>Rango de ancho de la Viga</b> | 3.22~7 in / 82~178 mm | <b>Radio Minimo de Giro</b>       | 3 ft / 1 m                                |
| <b>Normas</b>                    | ASME B30.17           | <b>Garantía</b>                   | 3 Year                                    |

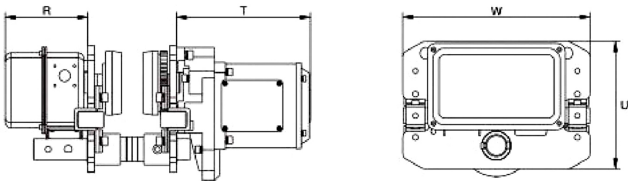

| Model / Modelo           | PWQE1Ti  | PWQE2Ti         | PWQE3Ti        | PWQE5Ti        | PWQE7Ti         | PWQE10Ti         |                |
|--------------------------|----------|-----------------|----------------|----------------|-----------------|------------------|----------------|
| Dimensions / Dimensiones | <b>W</b> | 12.4 in / 315mm | 12.7 / 325mm   | 13.3in / 340mm | 15.7 in/ 400mm  | 26.5 in / 670 mm | 19.6in / 500mm |
|                          | <b>U</b> | 8.3 in / 212mm  | 8.6mm / 220mm  | 9.8 in / 250mm | 11.4 in / 291mm | -                | 14.6in / 371mm |
|                          | <b>R</b> | 5.5 in / 142mm  | 5.5 in / 142mm | 5.5 in / 142mm | 5.5 in / 142mm  | 9 in / 231 mm    | 5.5 in / 142mm |
|                          | <b>T</b> | 9 in / 231mm    | 9 in / 231mm   | 9 in / 231mm   | 9 in / 231mm    | 5.6 in / 142 mm  | 9 in / 231mm   |

## Peso & Dimensiones

|                           |                  |
|---------------------------|------------------|
| <b>T Motor del Carro</b>  | 9.09 in / 231 mm |
| <b>R Carro Ancho Caja</b> | 6 in / 142 mm    |
| <b>A Altura Total</b>     | 10 in / 250 mm   |
| <b>W Ancho</b>            | 13.5 in / 340 mm |
| <b>Peso Total</b>         | 99 lbs / 45 Kg   |

## Detalles del Empaque

|                              |                  |
|------------------------------|------------------|
| <b>Paquete 1 Peso Neto</b>   | 90.2 lbs / 41 Kg |
| <b>Paquete 1 Peso Bruto</b>  | 99 lbs / 45 Kg   |
| <b>Paquete 1 Profundidad</b> | 22 in / 56 cm    |
| <b>Paquete 1 Ancho</b>       | 14 in / 36 cm    |
| <b>Paquete 1 Altura</b>      | 16 in / 41 cm    |

Referential Images / Imágenes Referenciales  
Specifications may change without notice / las especificaciones pueden cambiar sin previo aviso