



# 1,100 lbs. Davit Crane 360 Swivel Electric 110V Winch IP55

## Características Esenciales

- 1 Años de Garantía, Servicio y Atención al Cliente en Mexico

## Especificaciones Técnicas

<b>Capacidad de Carga</b>	1100 lbs / 500 kg	<b>Velocidad /min</b>	33 ft/10m @1line   16ft/5m @2line
<b>Numero de Velocidades</b>	1 Speed	<b>Voltaje</b>	1 Phase 110~120V 60Hz
<b>Codigo FCC</b>	OFNF21	<b>Clase de Servicio</b>	H2/M3/1Bm/Class B
<b>Potencia Motor</b>	1450 W	<b>AMP Motor</b>	8.5 AMP
<b>Freno Motor</b>	YES	<b>Grado de Aislacion</b>	B
<b>Protección IEC Motor</b>	IP40	<b>Cable</b>	ø11/64 in x 38 ft   ø4.3 mm x 12 m
<b>Humedad</b>	<85%	<b>Temperatura</b>	-4°~104° F / -20°~40° C
<b>Nivel de Ruido</b>	71 dB	<b>Normas</b>	Intertek 4006091 , UL N 1340, CAN/CSA C22.2 , EN14492-2 , EN60204-32
<b>Garantía</b>	1 Year		

BOOM Position	1100 lb - 0.5 t		
	1	2	3
A	1300 lbs	660 lbs	340 lbs
B	1150 lbs	580 lbs	290 lbs
C	1100 lbs	550 lbs	280 lb

BOOM Position	2200 lb - 1 t		
	1	2	3
A	2600 lbs	1300 lbs	780 lbs
B	2300 lbs	1150 lbs	690 lbs
C	2200 lbs	1100 lbs	660 lb

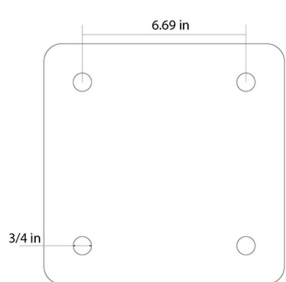
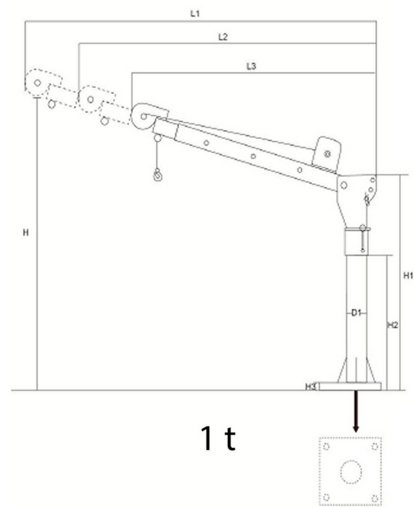
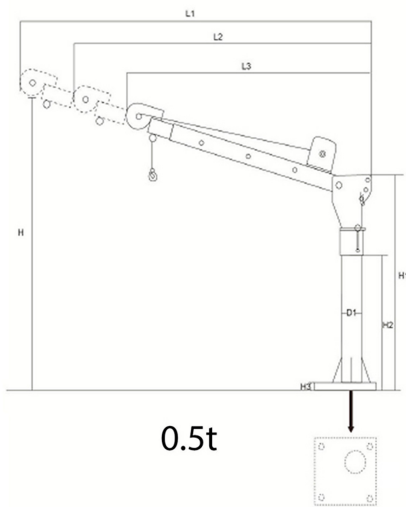

Variable	Capacity	
	1120 lb / 0.5 t	2240 lb / 1 t
H	82 in / 2082 mm	85 in / 2159 mm
H1	46.5 in / 1181 mm	47 in / 1193 mm
H2	30 in / 762 mm	
H3	3/4 in /	
L1	49 in / 1244 mm	51 in / 1295 mm
L2	42 in / 1066 mm	44 in / 1117 mm
L3	35 in / 889 mm	40 in / 1016 mm
D1	3.5 in / 88.9 mm	4 in / 101.6

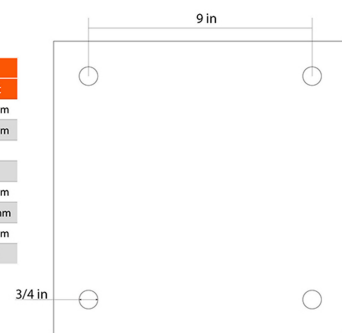

## Peso & Dimensiones

**Peso Total** 165 lbs / 75 Kg

## Detalles del Empaque

**Paquete 1 Peso Neto** 123 lbs / 56 Kg

**Paquete 1 Peso Bruto** 128 lbs / 59 Kg

**Paquete 1 Profundidad** 54 in / 138 cm

**Paquete 1 Ancho** 14 in / 36 cm

**Paquete 1 Altura** 14 in / 36 cm

**Paquete 2 Peso Neto** 35 lbs / 16 Kg

**Paquete 2 Peso Bruto** 37 lbs / 17 Kg

**Paquete 2 Profundidad** 21 in / 54 cm

