



2 Ton Top Running Motorized End Trucks Single Girder up to 57ft Span 220/440V 3P

Características Esenciales

- For heavy-duty class "C" single girder crane applications
- Drives and brakes are compatible with Variable Frequency Drive (VFD)
- Suitable for use on ASCE crane rail or square bar
- 3 Años de Garantía, Servicio y Atención al Cliente en Mexico

For heavy-duty class "C" single girder crane applications, Top running motorized end trucks. Include 2 trucks; 2 gear motors with D.C. brakes, rubber bumpers. All trucks are fully painted. Runway Rail ASCE # 30

Especificaciones Técnicas

Capacidad de Carga	2 Ton	Velocidad /min	66 ft
Numero de Velocidades	1 Speed - Optional Variable Speed	Voltaje	3 Phase 220~240/440~480V 60Hz
Potencia Total Watts	0.25 x 2	Luz Maxima	60 Ft
Material	Steel	Clase de Servicio	H4/M5/2m/Class D
Freno Motor	Yes	Protección IEC Motor	IP54
Variador de Frecuencia	Optional 1.1 Kw	Freno Dinámico	Only with VFD Optional
Control	Not Included. Optional single Speed, 2 Speed and Variable Speed	Rango de ancho de la Viga	Any
Normas	ASME / CMAA / Nch	Garantía	3 Year

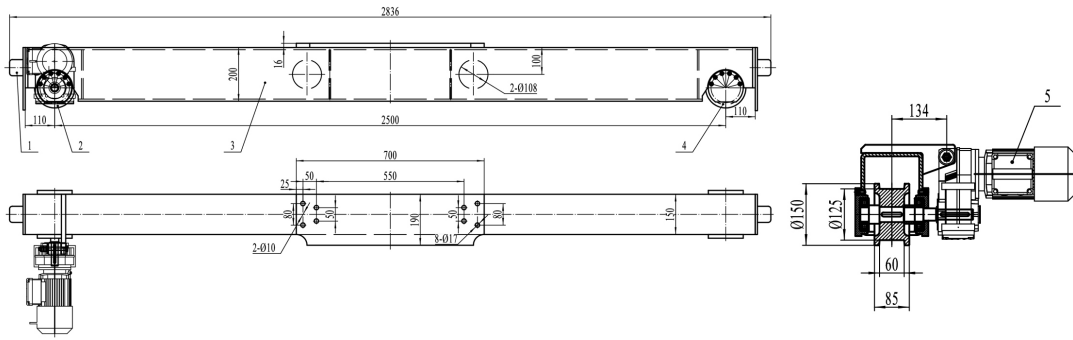

Peso & Dimensiones

Largo de testera	2500 mm
Peso Total	977 lbs / 444 Kg

Detalles del Empaque

Paquete 1 Peso Bruto	977 lbs / 444 Kg
Paquete 1 Profundidad	119 in / 303 cm
Paquete 1 Ancho	24 in / 61 cm
Paquete 1 Altura	31 in / 79 cm

Referential Images / Imágenes Referenciales
 Specifications may change without notice / las especificaciones pueden cambiar sin previo aviso