



## 5 Ton Manual Gantry Crane 11~15 ft Height 12 ft Span **MADE IN USA**

### Características Esenciales

- 3 Años de Garantía, Servicio y Atención al Cliente en Mexico

## Especificaciones Técnicas

Capacidad de Carga	5 ton	Alto de Viga	21 in
Overall SPAN	12 ft	Clear SPAN	10 ft
HUB Altura Libre Bajo la Viga	11 to 15 ft	Material	Steel
Factor de Diseño	4:1	Rango de ancho de la Viga	8.24 in
Fabricado en	USA	Garantía	3 Year

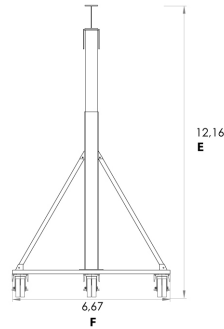
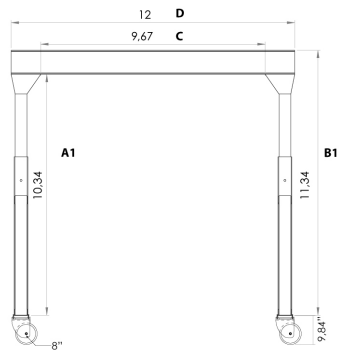

MODEL	PWMG5T-S12-H11-15a
A1	10,34 ft
B1	11,34 ft
C	9,6 ft
D	12 ft
E	12,16 ft
A2	14,34 ft
B2	15,34 ft
F	6,67 ft
G	16,16 ft

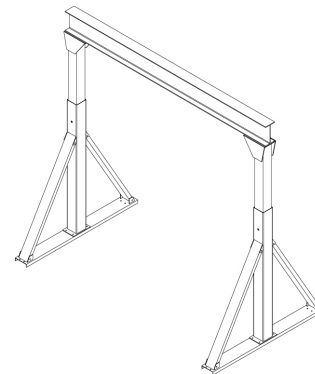
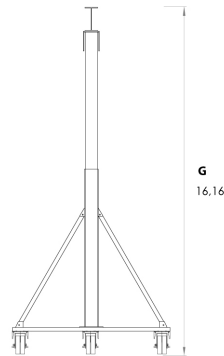
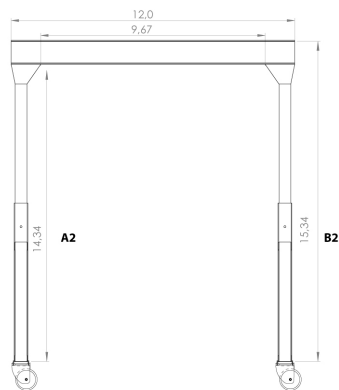

Referential Images / Imágenes Referenciales  
 Specifications may change without notice / las especificaciones pueden cambiar sin previo aviso